

APPLICATION: THIRD + FORTH AXLE ADDITION W/SPRING BRAKES

PART #: **PAKASB-2-B**

- CONTENTS:**
- Connectors as shown
 - Air tank with installed drain valve and plugged unused ports
 - Air tank mounting kit with pads, bolts, washers and lock nuts
 - Brake valve(s) are installed and include push to connect fittings
 - Hoses with swivel hose ends are installed to valve(s)
 - Hose separators

OPTIONAL SYSTEMS

PAKASB-2-S

SEALCO RELAY VALVE

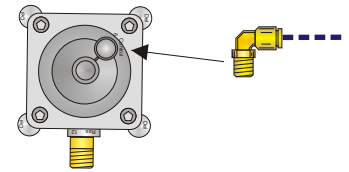

DA4407D (110415)

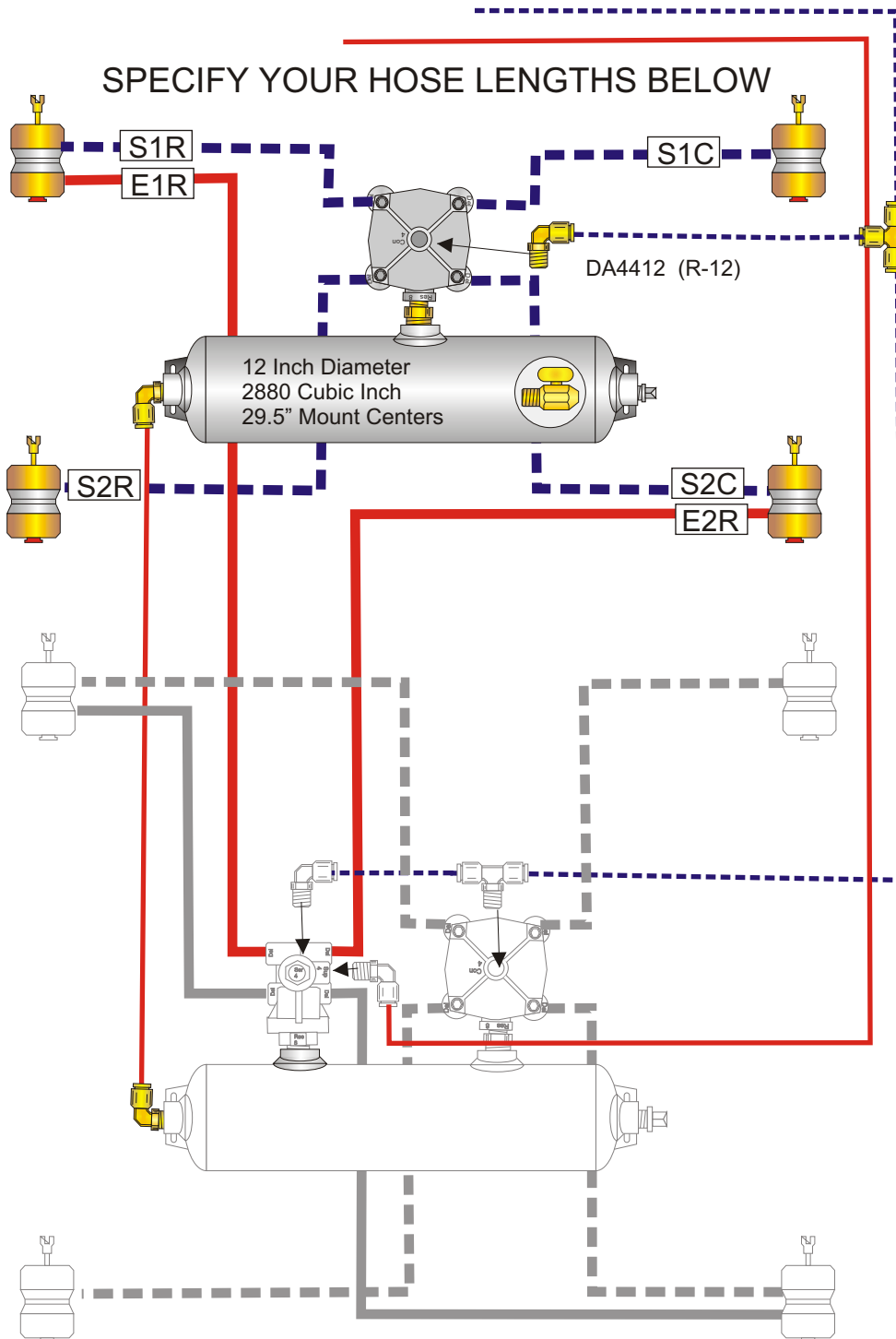

SUPPLIED WITH FOUR SPRING BRAKE CROSS OVER KITS

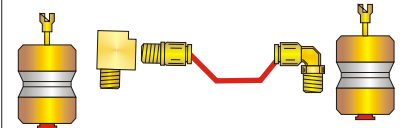

SPECIFY HOSE LENGTH IN INCHES EMERGENCY:

E1R	E1C
E2R	E2C
E3R	E3C
SERVICE:	
S1R	S1C
S2R	S2C
S3R	S3C
S4R	S4C

— — — Service Hose — — — Supply Hose
- - - - - Service Tube - - - - - Supply Tube

Specifications:

Hoses meet J1402 & JT106 specifications and are 3/8 ID unless otherwise noted. Reservoirs meet J10B specifications
 Pipe fittings are brass or plated SH80 steel. Push-in style 3/8 tube fittings standard. ABS Electronics pre-tested before shipment.